

Snede voorgevel / Nieuw  
Schaal: 1:50

Snede achtergevel - optie 1 / Nieuw  
Schaal: 1:50

Snede achtergevel - optie 2 / Nieuw  
Schaal: 1:50

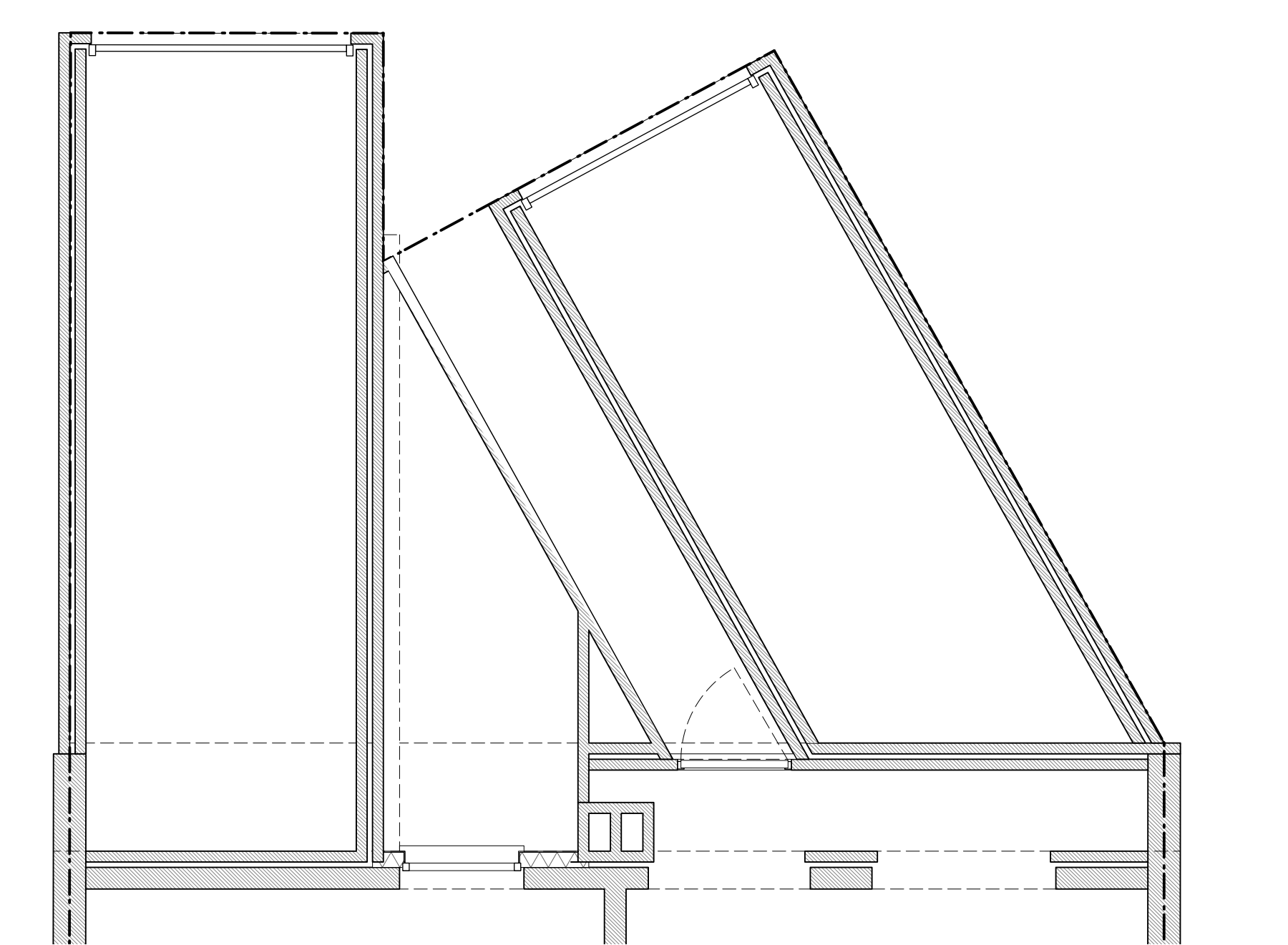

Nivo -1 / Nieuw  
Schaal: 1:50

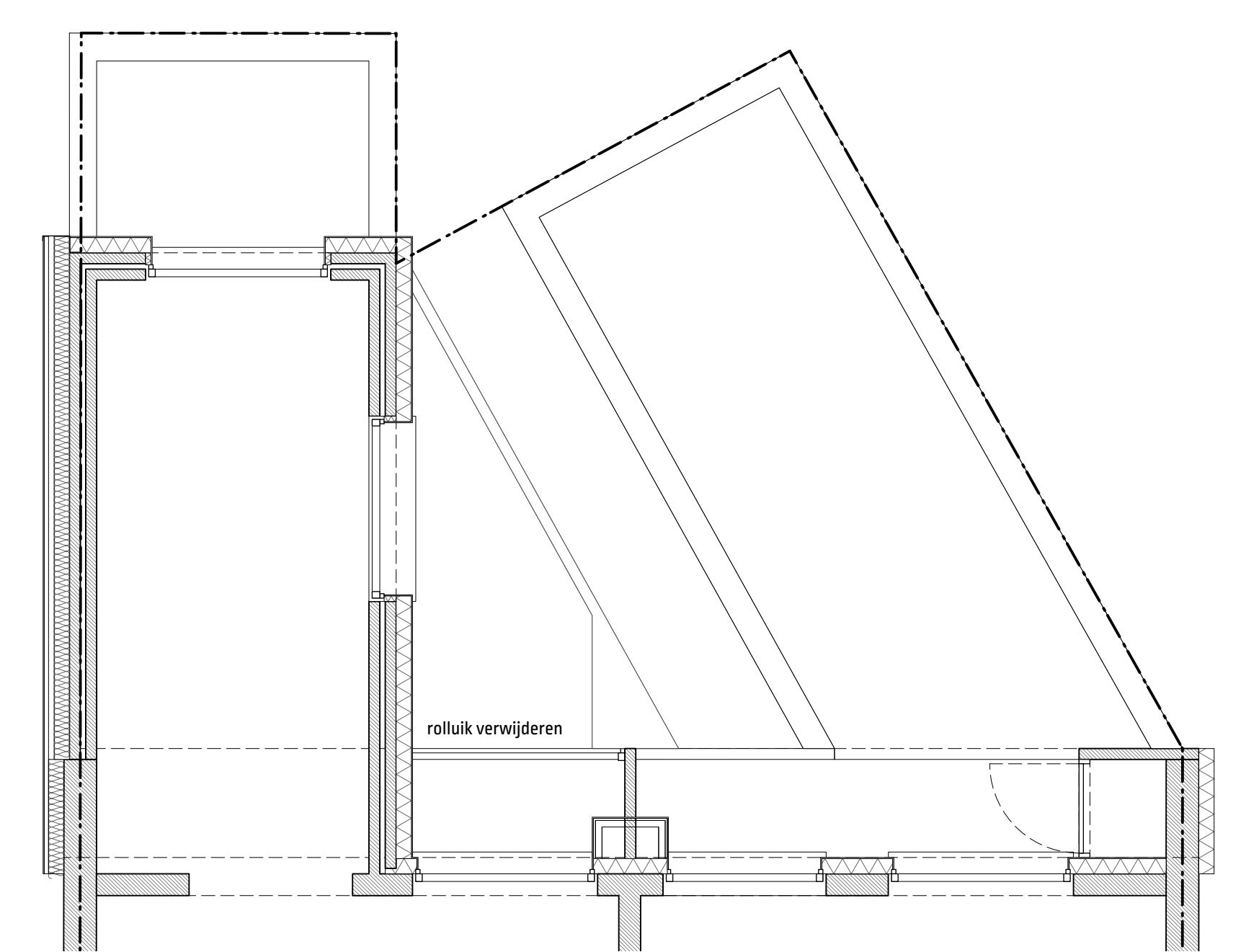

Nivo GV / Nieuw  
Schaal: 1:50

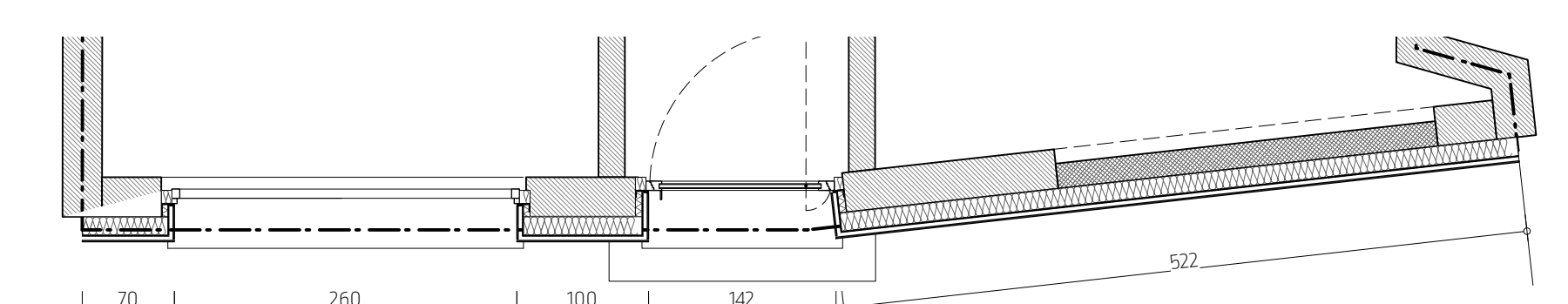

Nivo -1 / Nieuw  
Schaal: 1:50

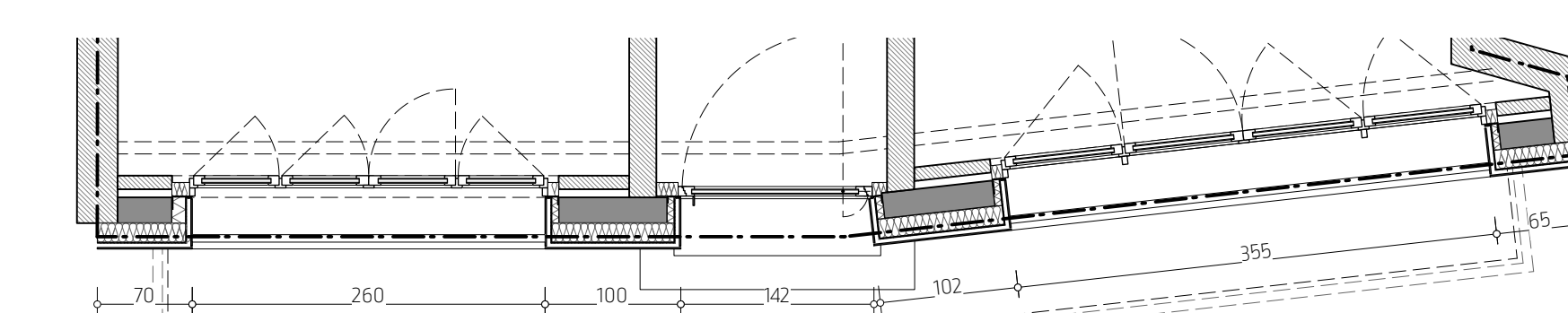

Nivo GV / Nieuw  
Schaal: 1:50

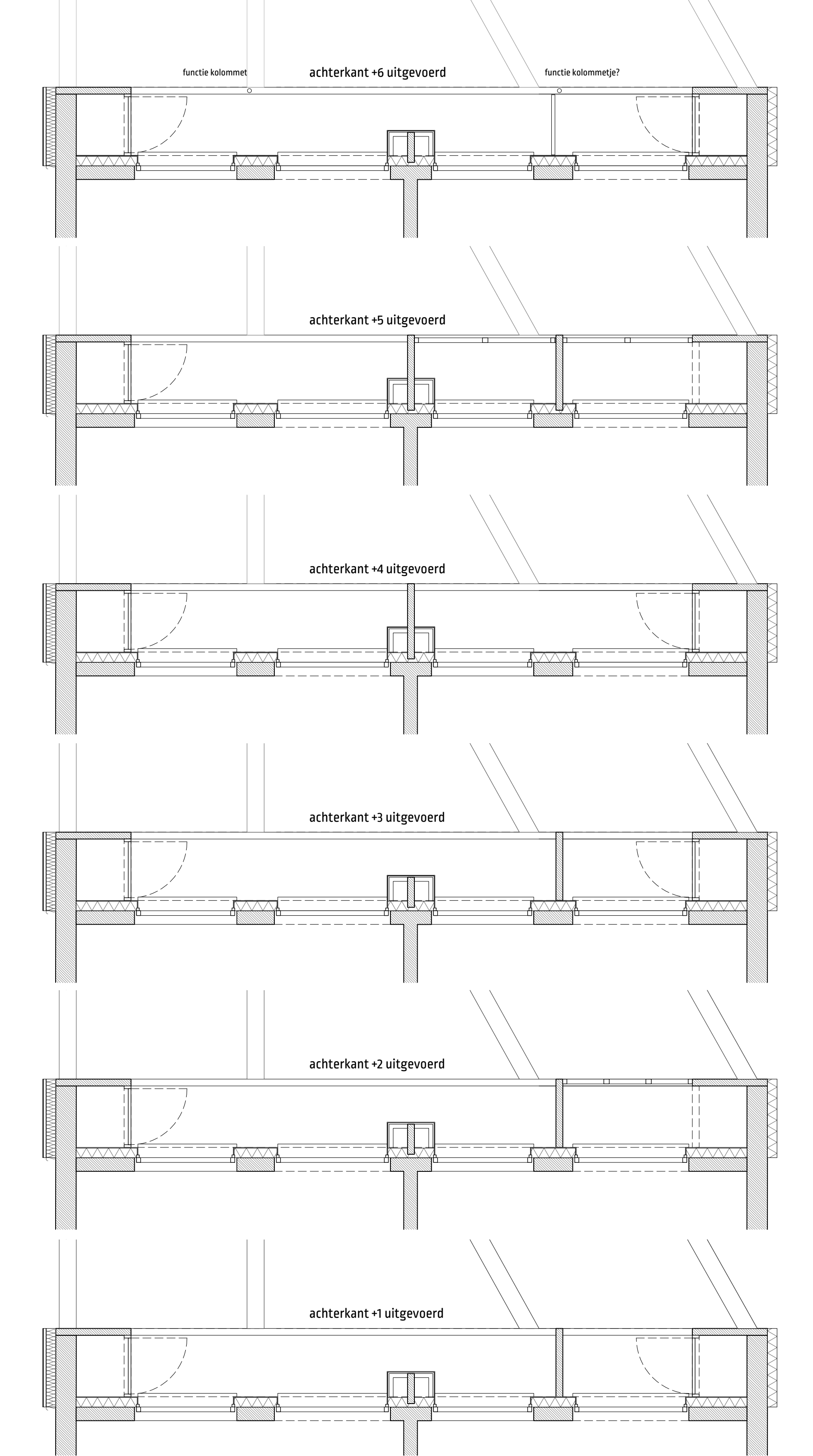

Nivo +1 tem +6 / Nieuw  
Schaal: 1:50

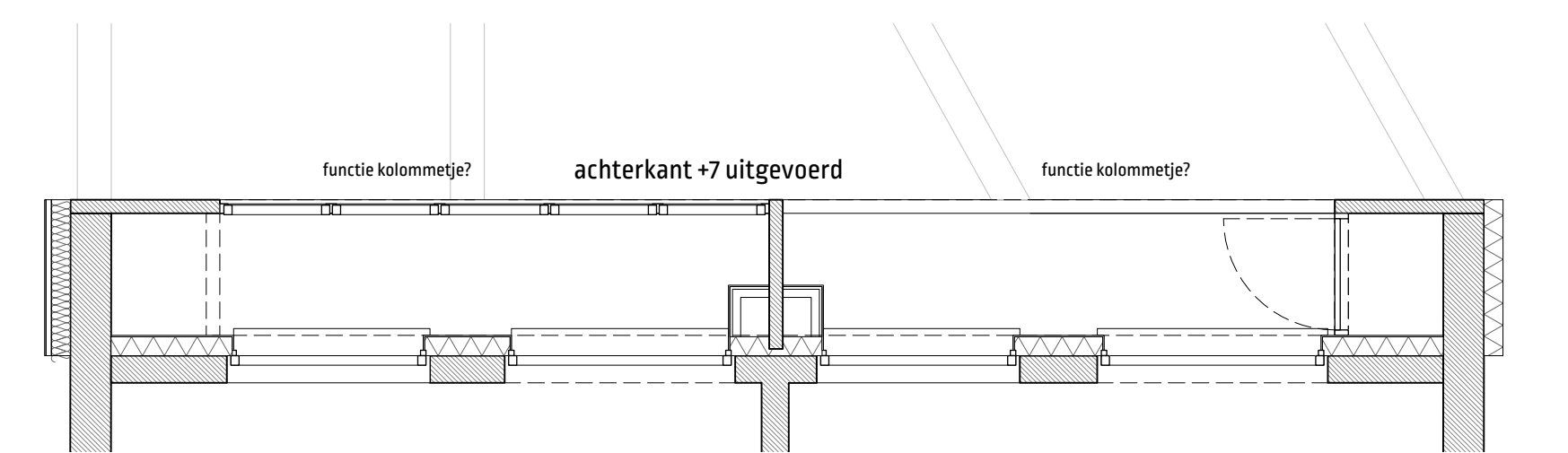

Nivo +7 / Nieuw  
Schaal: 1:50

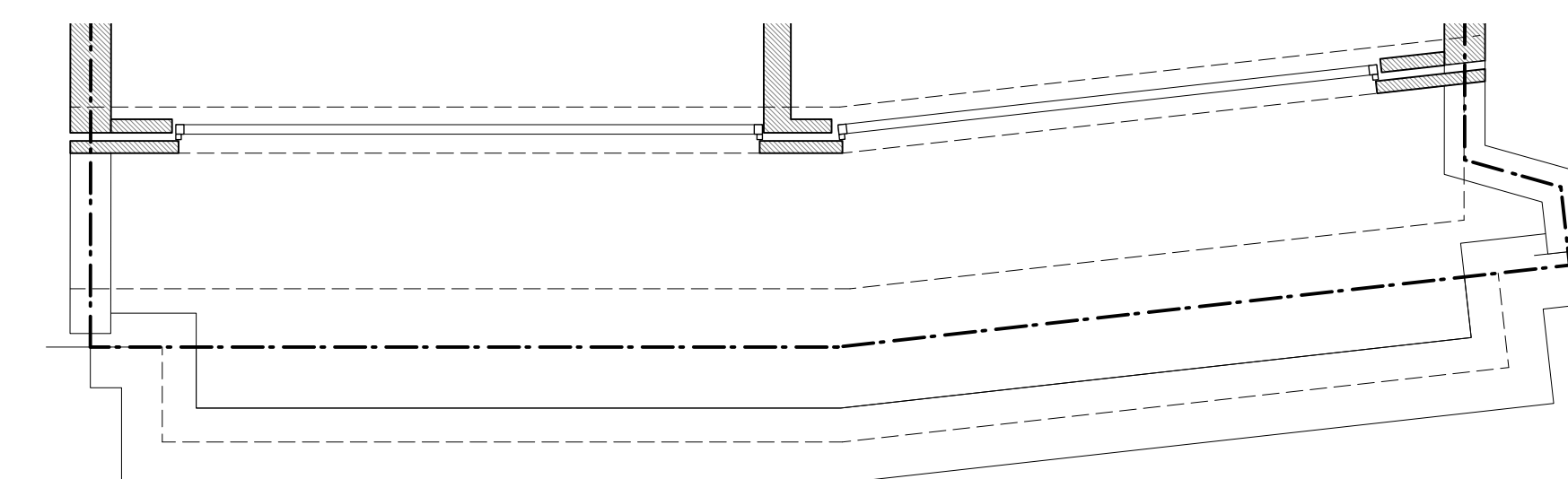

Nivo G +7 / Nieuw  
Schaal: 1:50

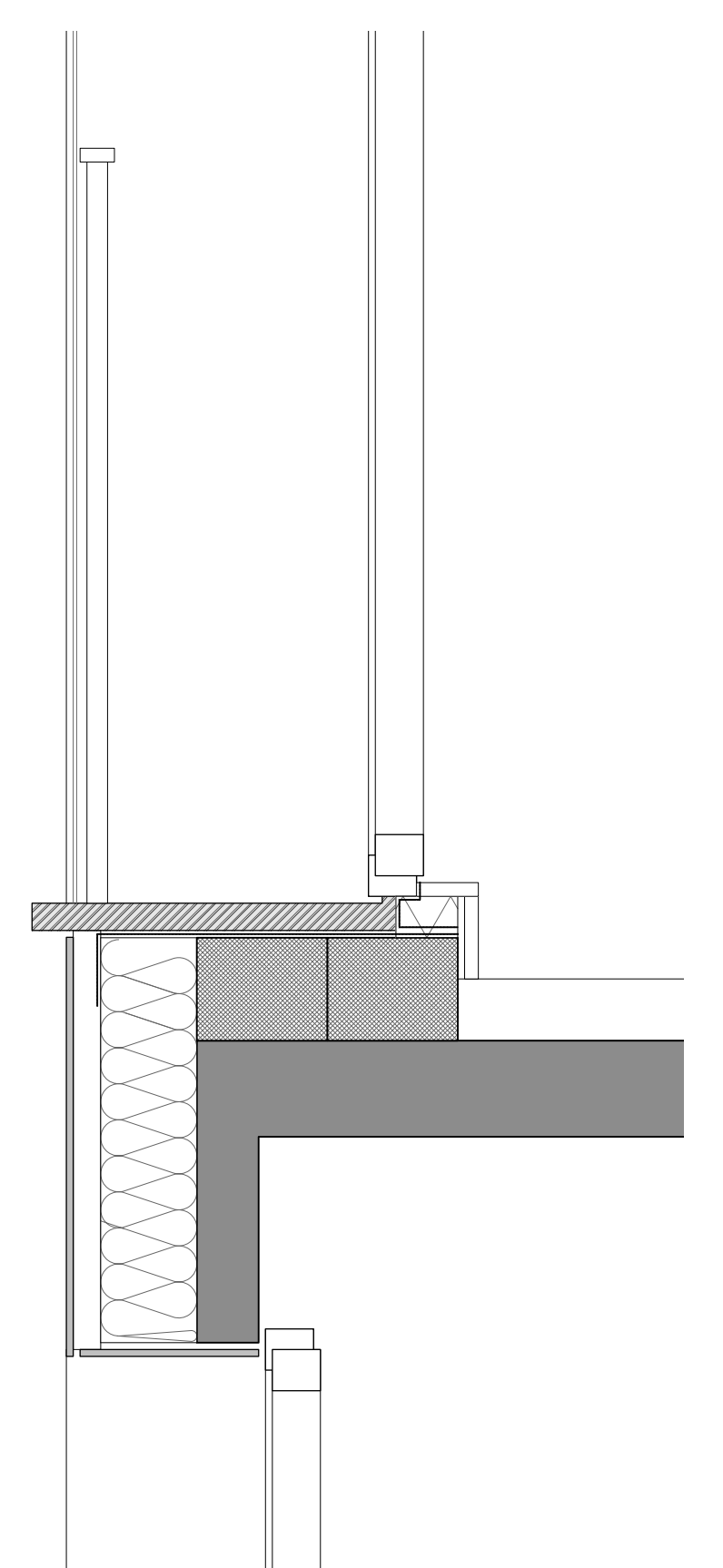

Detail 1  
Schaal: 1:10

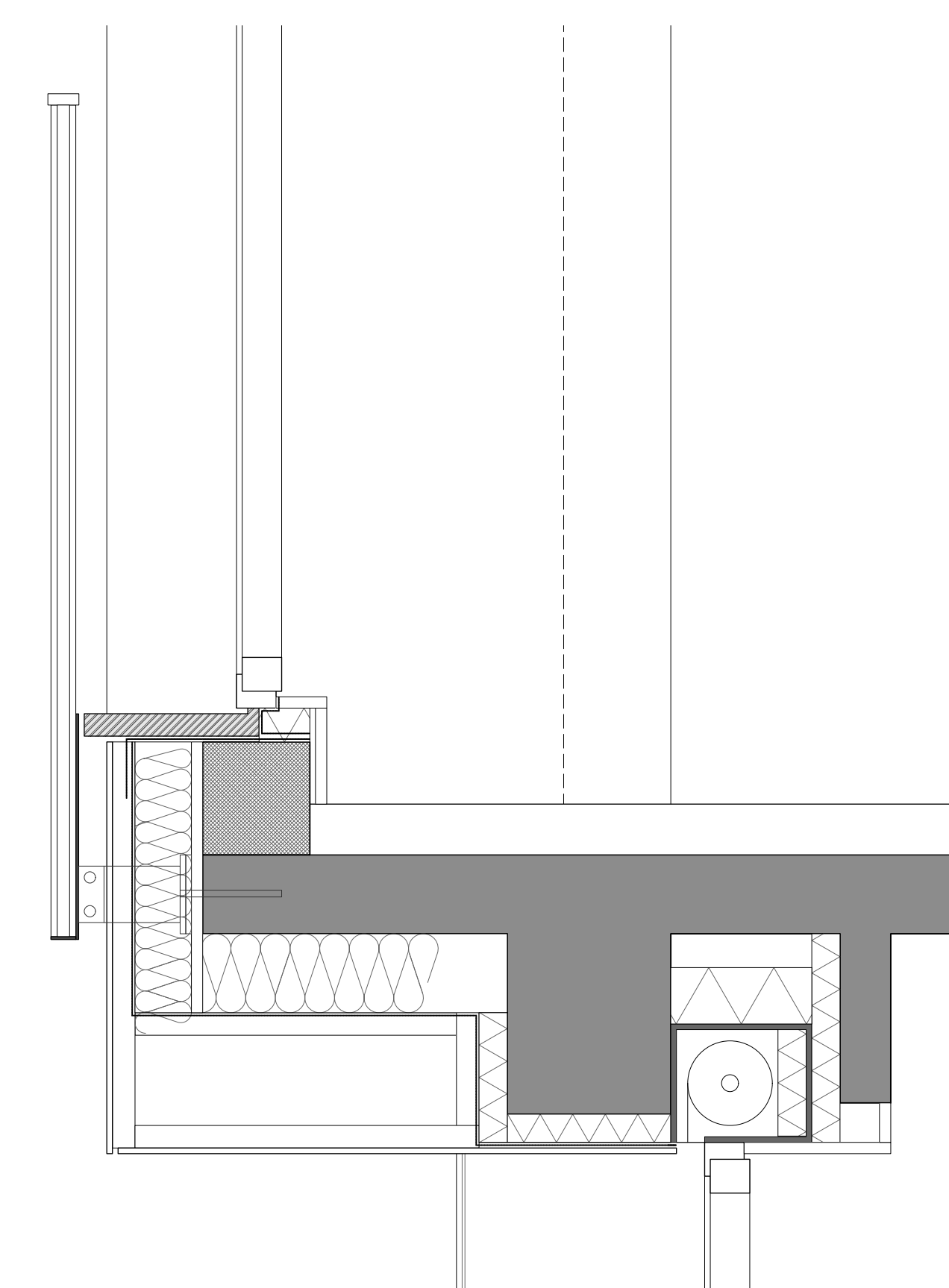

Detail 2  
Schaal: 1:10

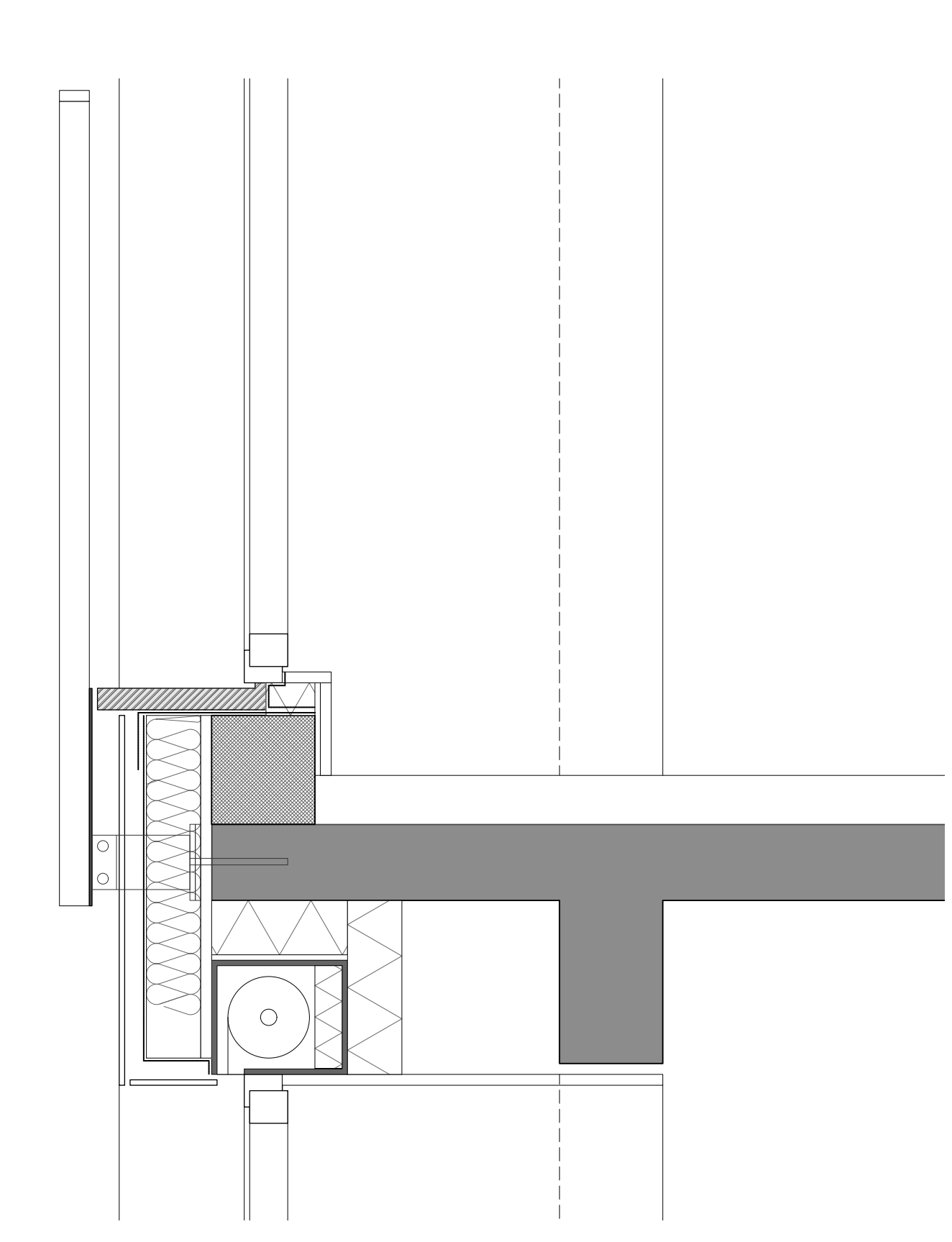

Detail 3  
Schaal: 1:10

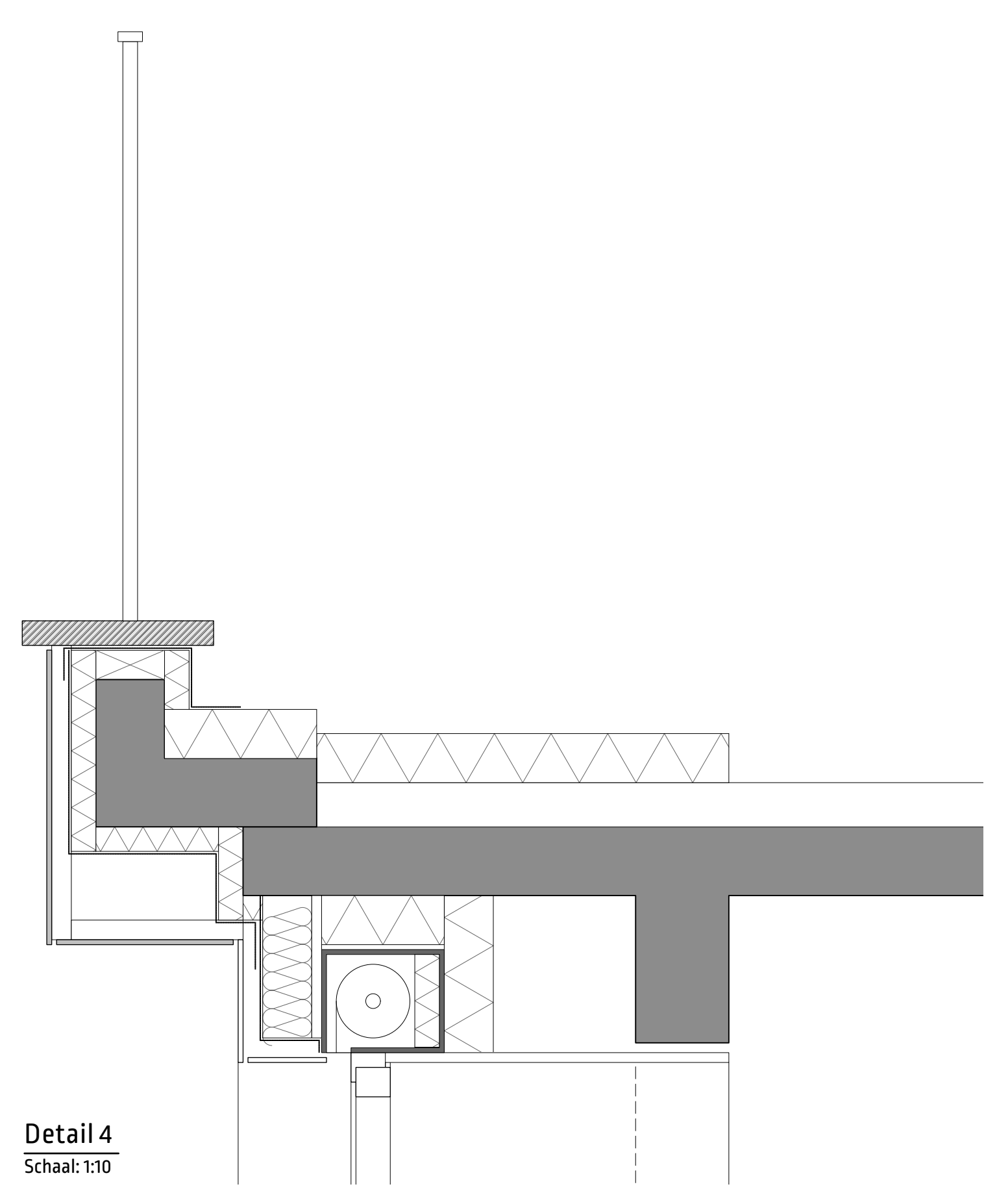

Detail 4  
Schaal: 1:10

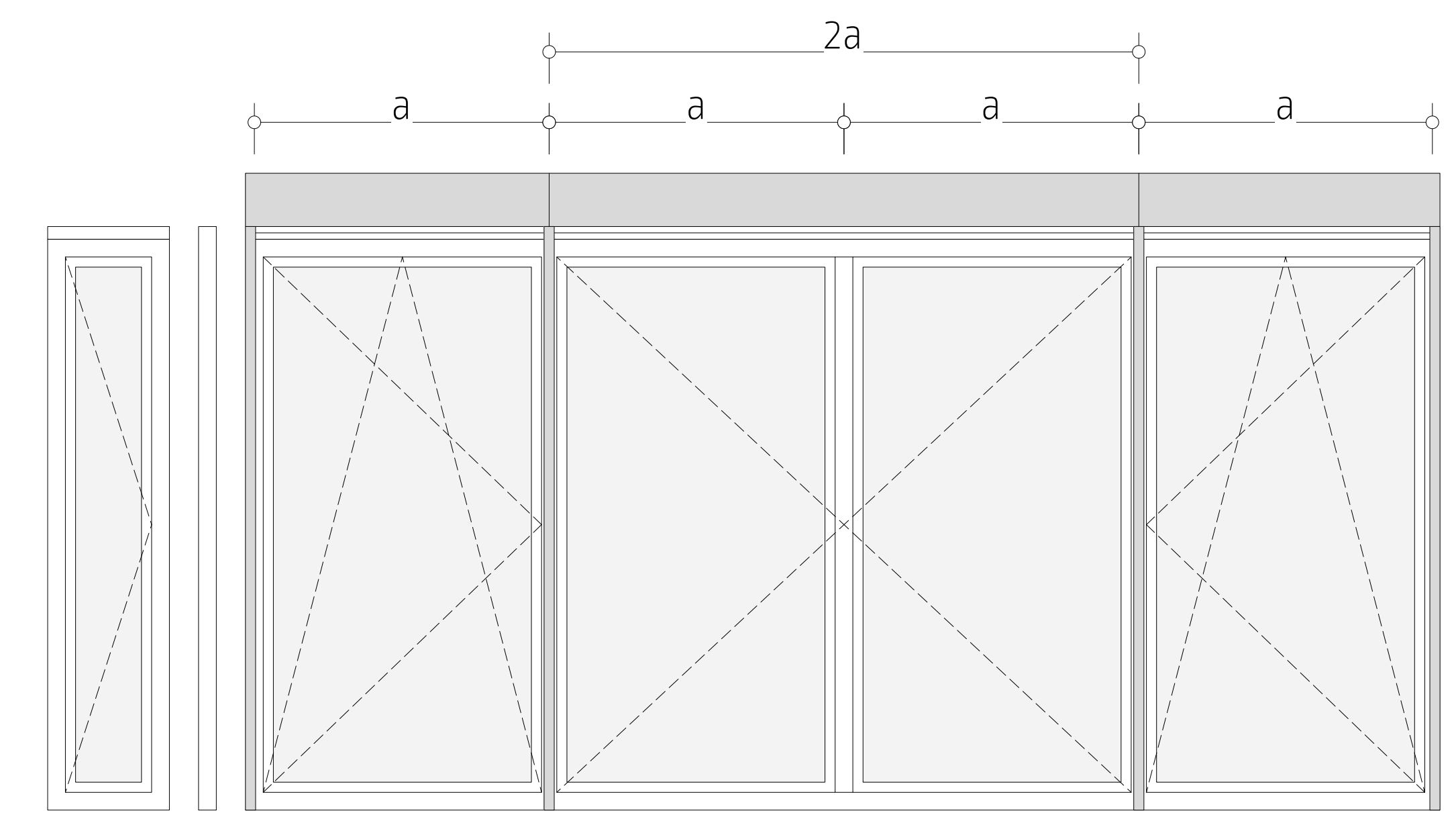

typeaanzicht ramen  
Schaal: 1:20

fase  
**AANBESTEDING**  
ontwerp

Isolerende renovatie van voor- en achtergevel

**Inhoud** inwendig met **schaal**

Nieuwe toestand	1:50
	1:20
	1:10

**gegevens van de bouwplaats** **gegevens van de bouwheer** **vertegenwoordiger(s)**

<b>Adres</b>	Koning Roberdyck 65	<b>Naam / firma</b>	VME Residentie "LAS VEGAS"
<b>Wijk/stad</b>	Wijkzone	<b>Adres</b>	1000 WILHELMINA LAURAGE
<b>Provincie</b>	West-Vlaanderen	<b>Adres</b>	BASA Westeniende
<b>Kadestraat</b>		<b>E-mail</b>	info@laplage.be
		<b>Tel/GSM</b>	

**datum** **index** **wijzigingen**

1  
2  
3

Kaaplein 1 - 6620 Nieuwpoort T 056 222 150  
info@architectenatelier.nl www.architectenatelier.nl

**ARCHITECTEN ATELIER**

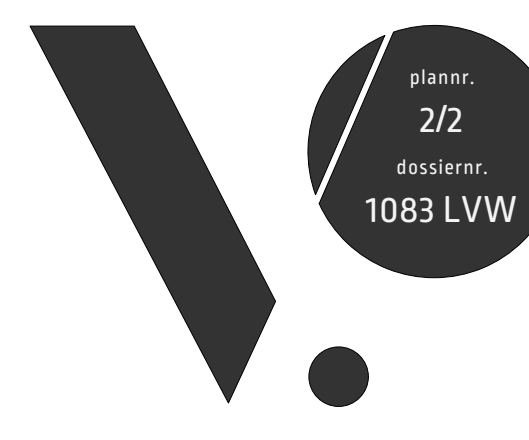

pagina 2/2  
document 1083 LW